

New as of:

02.2013

T1 / T2 / T3 highspeed handpiece

SN < 600 000

for Sirona, KaVo, W&H and NSK MachLite connection

Operating Instructions

English

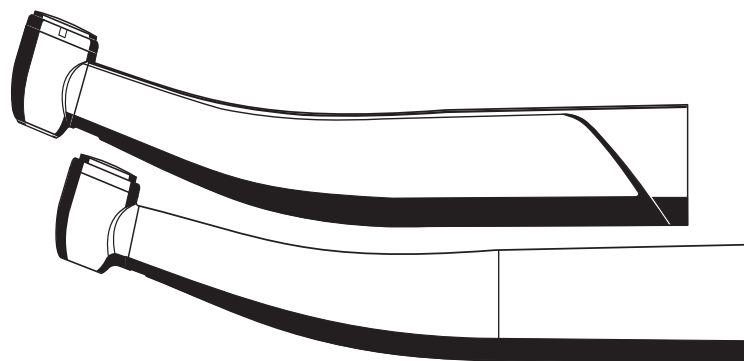

Table of Contents

1	Before you begin	4
1.1	Structure of the document	4
1.1.1	Labeling of information	4
1.1.2	Formats and symbols	5
1.2	Service life of Sirona instruments	5
2	Safety information	6
3	Technical description	7
3.1	Task	7
3.2	Structure of T1 turbine	7
3.3	Structure of T2 / T3 turbines	7
3.4	Technical data	8
3.5	Turbine connection types available	9
4	Preparation	10
4.1	Initial start-up and longer breaks in use	10
4.2	Prior to starting the work day	10
4.3	Before each patient	10
5	Operation	11
5.1	Connecting the Sirona quick coupling to the supply hose	11
5.2	Replacing the turbine	12
5.2.1	Turbine with Sirona or KaVo connection	12
5.2.2	Turbine with W&H or Bien-Air connection	12
5.2.3	Turbine with NSK MachLite connection	12
5.2.4	Turbine with NSK QD-J connection	12
5.3	Inserting and removing burr instruments	13
5.4	Adjusting the cooling spray	13
6	Follow-up	14
6.1	After each treatment session	14
6.2	At the end of the work day	14

7	Care and maintenance	15
7.1	Spraying the mechanical parts	15
7.2	Care of the push button chuck	16
7.3	Cleaning the light guide surfaces	16
7.4	Manually cleaning and disinfecting the surface.....	16
7.4.1	Cleaning the outer surface	16
7.4.2	Disinfecting the surface	17
7.5	Manually cleaning and disinfecting the spray channels	17
7.6	Automated cleaning and disinfecting	17
7.6.1	... with a DAC UNIVERSAL	17
7.6.2	... with cleaning and disinfection equipment.....	17
7.7	Sterilization.....	18
7.8	Cleaning the cooling spray nozzles.....	18
7.9	Replacing the spray insert.....	19
7.10	Testing the FG clamping system.....	20
7.11	Servicing Sirona quick coupling	20
7.11.1	Replacing O-rings	20
7.11.2	Replacing the compression ring	20
7.11.3	Replacing the halogen lamp/LED.....	21
7.11.4	Replacing the spray water cartridge.....	21
7.11.5	Replacing the felt strip (quick coupling F)	21
7.12	Replacing the halogen lamp in the handpiece	22
8	Spare parts and consumables.....	24
9	Storage and transport conditions.....	26
10	Disposal.....	27

1 Before you begin ...

Intended use

The T1 / T2 / T3 turbine is used to treat dental disease and injuries.

The treatment involves the rotary processing of hard and soft tooth substance and dental prostheses (crowns, fillings, bridges, etc.).

The T1 / T2 / T3 turbine corresponds with the provisions of state-of-the-art technology. The T1 / T2 / T3 turbine complies with the ISO 14457 and ISO 9168 standards.

1. Read the operating instructions before using the T1 / T2 / T3 turbine.
2. Use the T1 / T2 / T3 turbine only for the purposes described in the operating instructions.
3. Follow the hygiene regulations, work safety regulations, and accident prevention measures that apply to the T1 / T2 / T3 turbine.

Target group

This product is intended only for use by trained dental personnel in dental practices and laboratories.

Scope of validity of operating instructions

These operating instructions are applicable for the following turbines:

- T1 / T2 / T3 up to serial number 600000

1.1 Structure of the document

1.1.1 Labeling of information

Warnings

- To prevent personal injury, please observe all warnings.

Warnings are labeled as follows:

DANGER! indicates a hazard **that will lead** to death or serious injury if not avoided.

WARNING! indicates a hazard that **can lead** to death or serious injury if not avoided.

CAUTION! indicates a hazard that **can lead** to injury if not avoided.

Instructions for use

- To prevent material damage and additional expenses, please observe all instructions for use.

Instructions for use are labeled as follows:

NOTICE! indicates measures for the prevention of material damage.

IMPORTANT: indicates information on avoiding additional expenses and other important information.

Tip: indicates information on facilitating work.

1.1.2 Formats and symbols

The formats and symbols used in this document have the following meaning:

✓ Prerequisite 1. First action step 2. Second action step or > Alternative action ↪ Result	Requests you to do something.
Use of formats and symbols [→ 5].	Identifies a reference to another text passage and specifies its page number.
• List	Identifies a list.

1.2 Service life of Sirona instruments

When used as intended:

- Non-moving parts of Sirona instruments have a typical service life of approx. 5 years
- Moving parts of Sirona instruments have a typical service life of approx. 3 years

No warranty claim can be inferred here, as wear may occur earlier or later than indicated above depending on use, frequency of sterilization, and frequency of maintenance.

2 Safety information

Obligations of the user

- Use only fault-free materials that do **not** deviate from the specified data [→ 8].
- Protect yourself, patients, and others against hazards. To do this, follow the safety instructions.
- Use the equipment as intended.
- You should always keep these operating instructions within reach for further reference.

Preventing the spread of infections and cross contamination

Prevent the spread of infections and cross contamination among patients, users, and third parties. Sterilize equipment after each patient.

Take the appropriate hygiene measures, e.g. wear protective gloves.

Prevention of eye damage

The LED is in risk class 2 according to the IEC 62471:2006 standard. The LED emits optical radiation that is potentially hazardous and may be harmful to the eyes! Potential damage to the retina from the blue light emission. Do not stare at the LED for longer periods of time while in operation.

Malfunction or damage

Immediately discontinue use in the case of malfunction or damage. Damaged turbines may cause injury. Notify the dental depot or the manufacturer.

Potential explosion hazard

Do **not** use this product in areas subject to explosion hazards.

Repair

Do **not** attempt to repair the turbine yourself.

The replacement of bearings can lead to sudden failures and injuries to patients due to the different levels of wear of the newer and older components. Safe operation is **not** guaranteed when repairs are performed incorrectly. For repairs, contact the dental depot or the manufacturer.

Spare and accessory parts

Use only Sirona original or approved parts. Safe operation is **not** guaranteed for parts that have not been approved by Sirona.

If you have any questions, please contact your dental depot or the manufacturer.

3 Technical description

3.1 Task

The T1 / T2 / T3 turbine is used to power dental instruments with an FG shank.

The quick coupling is used for media supply and connection to the supply hose and features convenient turnability.

3.2 Structure of T1 turbine

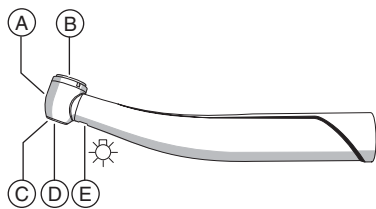

A	Turbine head (here: CONTROL)
B	Push button
C	Cooling spray outlet
D	Opening of chuck system
E	Light aperture

3.3 Structure of T2 / T3 turbines

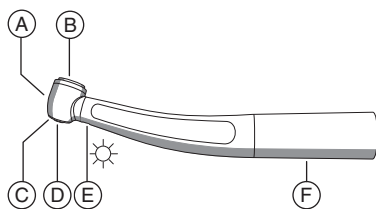

A	Turbine head (here: Racer)
B	Push button
C	Cooling spray outlet
D	Opening of chuck system
E	Light aperture (only for T2 turbine)
F	Handpiece sleeve

3.4 Technical data

Turbine T1 / T2 / T3

		T1 turbine	T2 turbine	T3 turbine
Available head sizes:				
	CONTROL	x	x	-
	Racer	-	-	x
	mini	x	x	x
Light function		x	x	-
Anti-retraction in head housing		x	x	x
Back suction stop in the spray water area		x	x	x
Pushbutton cover clamping system		FG	FG	FG

Turbine head

	CONTROL	Racer	mini
Idling speed in min^{-1}	250 000 + 20%	400 000 \pm 10%	420 000 \pm 10%

Friction grip burr instrument

	CONTROL	Racer	mini
Shank standard	ISO 1797-1	ISO 1797-1	ISO 1797-1
Shank diameter in mm	1.59 - 1.60	1.59 - 1.60	1.59 - 1.60
Maximum total length in mm	25	25	21
Maximum working diameter in mm (ISO 2157)	2.1	2.1	2.1





Treatment center

	T1 / T2 / T3
Driving air pressure in bar (flowing, dry, and clean)	2.7 \pm 0.1
Return air pressure in bar	< 0.15
Air consumption in NI/min	43 \pm 4
Spray air pressure in bar	2.7 \pm 0.2
Spray water pressure in bar	2.0 \pm 0.2
Recommended water content of spray	> 50 ml/min

Quick couplings (Sirona)

	Quick coupling R	Quick coupling F	Quick coupling B
Connection	6-hole	6-hole	4-hole
Standard	ISO 9168	ISO 9168	ISO 9168
Driving air return	with return airflow	without return airflow	without return airflow
Spray water control	at the coupling	at the coupling	-
Back suction stop	in the spray water area	in the spray water area	in the spray water area
Light function	x	x	-
Lamp voltage (lamp with dark brown socket)	3.6 V	3.6 V	-
Lamp voltage (LED)	3.6 V	3.6 V	-

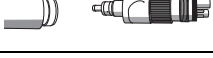
3.5 Turbine connection types available

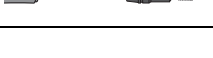
	Connection type available for	T1 turbine	T2 turbine	T3 turbine
	R/F quick coupling (Sirona)	x	x	-
	Quick coupling B	-	-	x
	Multiflex LUX (KaVo) quick coupling	x	x	-
	ROTO QUICK (W&H) quick coupling	x	x	x
	Unifix L (Bien-Air) quick coupling	x	x	x
	MachLite/Phatelus (NSK) quick coupling	-	x	x
	QD-J (NSK) quick coupling	-	-	x

4 Preparation

4.1 Initial start-up and longer breaks in use

- Sterilize the turbine and accessory parts prior to startup.
- Clean and maintain the turbine after longer breaks in use.

4.2 Prior to starting the work day

- Purge the water and air channels for 20-30 seconds.

4.3 Before each patient

1. Purge the water and air channels for 20 - 30 seconds.
2. Attach the turbine [→ 12].
3. Insert the burr instrument [→ 13].
4. Use a sufficient amount of cooling water (> 50 ml/min) [→ 13].
5. Use filtered water only (< 50µm).
6. Check the nozzles for blockages and lime deposits, for example, and clean the nozzles if necessary [→ 18].

CAUTION! Insufficient cooling leads to overheating of the preparation site and damage to the tooth substance. Ensure that the water content is > 50ml/min.

5 Operation

NOTICE! Use only burs and diamond polishers that are sharp and undamaged. Use clean burs and diamond polishers to avoid dirt in the clamping system.

CAUTION! A loose or partially removed burr instrument can detach itself from the head or break off. This may cause injury. Therefore, use the turbine only if the burr instrument is inserted at least 10 mm and is clamped securely in place.

CAUTION! Insufficient cooling leads to overheating of the preparation site and damage to the tooth substance. Ensure that the water content is > 50 ml/min.

CAUTION! Do not pull the patient's cheek back with the handpiece while the turbine is rotating. This would actuate the push button, thus creating a risk of burning the patient's oral mucosa.

CAUTION! Potentially hazardous optical radiation may cause harm to the eyes. Do **not** stare at the LED for extended periods during operation.

5.1 Connecting the Sirona quick coupling to the supply hose

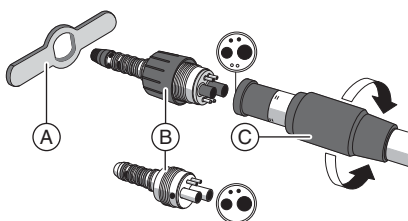

1. Attach the quick coupling (B) to the supply hose, noting the various tube diameters.
2. Screw the cap nut (C) tight. Secure the quick coupling using the key (A).

5.2 Replacing the turbine

CAUTION! Do not remove the handpiece while the turbine is running.

5.2.1 Turbine with Sirona or KaVo connection

Attaching the turbine

- Insert the turbine until it audibly clicks into place.

Removing the turbine

- ✓ The turbine is at a standstill.
- Hold the quick coupling and the hose nut firmly and pull the turbine while turning it slightly. Do **not** pull on or hold the supply hose.

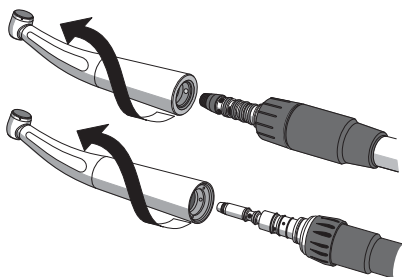

5.2.2 Turbine with W&H or Bien-Air connection

Attaching the turbine

- Insert the turbine until it audibly clicks into place.

Removing the turbine

- ✓ The turbine is at a standstill.
- Press the markings (A) of the W&H quick coupling or the pushbuttons (B) on the Bien-Air quick coupling and remove the turbine, turning it slightly. Do **not** pull on or hold the supply hose.

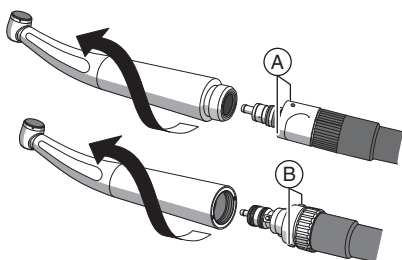

5.2.3 Turbine with NSK MachLite connection

Attaching the turbine

- Insert the turbine until it audibly clicks into place.

Removing the turbine

- ✓ The turbine is at a standstill.
- Slide back the sleeve (A) on the quick coupling toward the supply hose and pull the turbine while turning it slightly. Do **not** pull on or hold the supply hose.

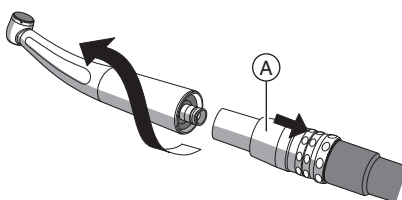

5.2.4 Turbine with NSK QD-J connection

Attaching the turbine

- Slide back sleeve (A) on the quick coupling toward the supply hose and insert the turbine.

Removing the turbine

- ✓ The turbine is at a standstill.
- Slide back the sleeve on the quick coupling toward the supply hose and detach the turbine while turning it slightly. Do **not** pull on or hold the supply hose.

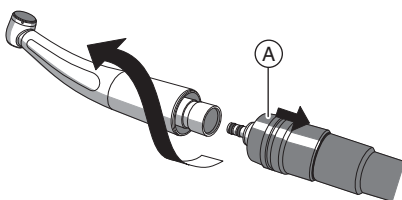

5.3 Inserting and removing burr instruments

IMPORTANT: Check the push button to make sure it moves freely!

NOTICE! Use only burs and diamond polishers that are sharp and undamaged. Use clean burs and diamond polishers to avoid dirt in the clamping system.

CAUTION! A loose or partially removed burr instrument can detach itself from the head or break off. This may cause injury. Therefore, use the turbine only if the burr instrument is inserted at least 10 mm and is clamped securely in place.

Inserting the friction grip burr instrument

- ✓ The turbine is at a standstill.
- 1. Press the button and slide the burr instrument in until it reaches the stop.
- 2. Pull on the burr instrument to check that it is firmly attached.

Removing the friction grip burr instrument

- ✓ The burr instrument must not be moving.
- > Press the button and remove the burr instrument.

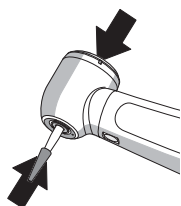

5.4 Adjusting the cooling spray

- > Adjust the cooling spray for **quick coupling B** at the treatment center.
- > Adjust the cooling spray for **QD-J quick coupling (NSK)** at the treatment center.
- > Adjust the flow rate of the cooling water using the control ring (A) (> 50 ml/min).

Tip: You can measure the amount of cooling water with a measuring cup and watch.

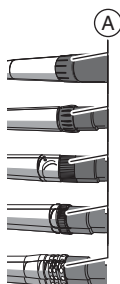

Water flow

R/F (Sirona) quick coupling: The maximum water flow is set when the control ring clicks into place.

KaVo quick coupling: The maximum water flow is set when the two markings face each other.

W&H quick coupling: The minimum water flow is set when the red line and the red dot are facing each other.
Turn the control ring to the left or right for the maximum water flow.

Bien-Air quick coupling: The minimum water flow is set when the control ring is rotated right to the stop.
The maximum flow is set when the control ring is rotated left to the stop.

MachLite quick coupling (NSK): The maximum water flow is set when the control ring clicks audibly into place.

6 Follow-up

6.1 After each treatment session

1. Clean and disinfect the turbine and accessories.
2. Spray the turbine [→ 15].
3. Sterilize the turbine and the accessories [→ 18].

6.2 At the end of the work day

- Spray the turbine [→ 15].

7 Care and maintenance

Elastomers, e.g. O-rings, must be replaced depending on their degree of wear.

7.1 Spraying the mechanical parts

Intervals

- At least every noon and evening
- Prior to each sterilization
- After each thermodisinfection
- During a longer preparation (> 10 minutes)

Required accessories

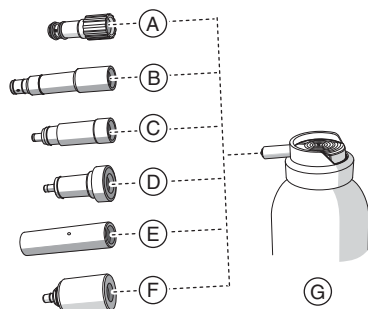

- A Sirona connection spray adapter
- B KaVo connection spray adapter
- C W&H connection spray adapter
- D Bien-Air connection spray adapter
- E NSK MachLite connection spray adapter
- F NSK QD-J connection spray adapter
- G T1 Spray

NOTICE! Using sprays from other manufacturers can reduce the product's service life. Use only Sirona T1 spray.

Procedure

- ✓ The turbine is at a standstill.
 - ✓ The O-rings on the spray adapter are intact.
1. Remove the burr instrument.
 2. Detach the turbine from the quick coupling [→ 12].
 3. Attach the spray adapter onto the nozzle of the spray can as shown.
 4. Insert the turbine as far as it will go and hold it in place.
 5. Spray into the turbine for 1-2 seconds.
IMPORTANT: Hold the spray can upright.

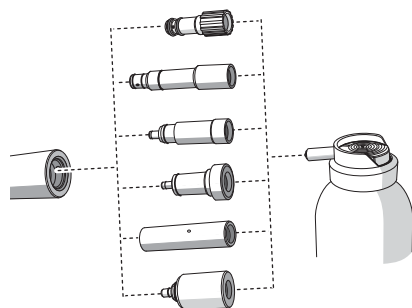

Check

1. Check whether the fluid coming out of the turbine head is clean.
2. If the fluid is dirty, repeat the process.

Is the fluid still not clean?

1. Connect the turbine to the quick coupling and allow the turbine to run briefly. In this way, the spray can be distributed more effectively.
2. **CAUTION!** Wait until the turbine comes to a standstill. Wipe off any leaking oil with a dry cloth.
3. Repeat the spraying procedure.

7.2 Care of the push button chuck

Use T1 spray on the push button chuck to remove deposits and ensure proper functioning of the clamping system.

Interval

Carry out maintenance work on the push button chuck at least once a week.

Required accessories

T1 spray

Procedure

1. Press the turbine head with the chuck firmly against the spray can nozzle.
2. Spray the chuck for 1 - 2 seconds.
IMPORTANT: Hold the spray can upright.
3. Wipe off any leaking protective oil with a lint-free cloth.

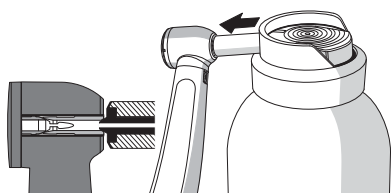

7.3 Cleaning the light guide surfaces

1. In order to avoid scratching the surfaces (A), blow off any dirt particles with air using a dry syringe.
2. Wipe the surfaces with a Q-tip or a soft cloth and alcohol.

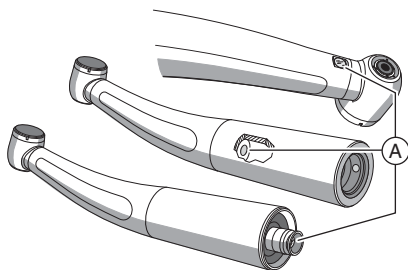

7.4 Manually cleaning and disinfecting the surface

✓ Wear appropriate protective clothing.

1. Remove the burr instrument [→ 13].
2. Use automated processing when possible.

IMPORTANT: Manual cleaning must always be combined with disinfection.

7.4.1 Cleaning the outer surface

NOTICE! Never clean in an ultrasonic bath!

1. Clean the turbine by brushing it off under running water (< 38°C, < 100°F, at least drinking water quality).
2. Blow the turbine out with max. 3 bar.

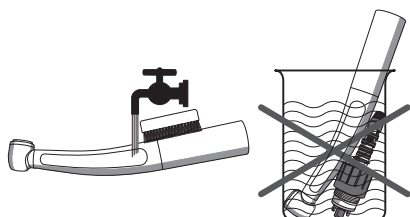

7.4.2 Disinfecting the surface

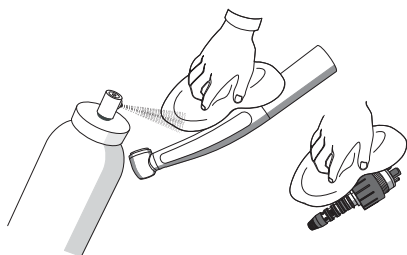

NOTICE! Never immerse in disinfectants!

✓ The disinfectants must be approved in your country and have proven bactericidal, fungicidal and virucidal properties.

1. Spray the surface with disinfectant.
2. Wipe the disinfectant away with a cloth.

In the USA and Canada, for example, you can use:

- CAVICIDE®
- CAVIWIPES™

Please observe the manufacturer's instructions for using instrument disinfectants.

7.5 Manually cleaning and disinfecting the spray channels

- Clean and disinfect the spray channels using suitable equipment and the corresponding adapters in accordance with the manufacturer specifications.

7.6 Automated cleaning and disinfecting ...

NOTICE! Do **not** carry out automated cleaning of the quick couplings.

7.6.1 ... with a DAC UNIVERSAL

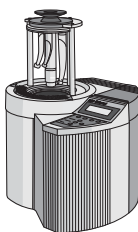

We recommend using **Sirona DAC UNIVERSAL** for automated cleaning, disinfection, and care.

For further details, refer to the operating instructions supplied with the unit.

- Manual care of the push button chuck [→ 16].

7.6.2 ... with cleaning and disinfection equipment

The turbine can also be cleaned and disinfected in suitable cleaning and disinfection equipment.



The cleaning and disinfection equipment used must be approved by its manufacturer for the cleaning and disinfection of dental instruments and comply with EN ISO 15883-1 (e.g. 95°C/203°F and 10 min. holding time).

For further details, refer to the operating instructions supplied with the unit.

1. Check whether the turbine is clean after processing.
2. If it is still dirty, repeat the process.
 - ✎ For further processing, the turbine should be dry and free of residue.
3. Blow the turbine out with max. 3 bar.
4. Manual care of mechanical parts [→ 15].
5. Manual care of the push button chuck [→ 16].

7.7 Sterilization

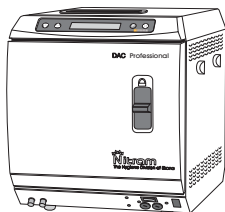
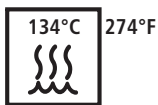

1. Clean and disinfect the turbine. [→ 16]
2. Spray the turbine [→ 15].
3. Sterilize the turbine in the steam sterilizer with saturated water vapor.

Saturated water vapor: Temperature: 134°C (274°F)

Overpressure: 2.04 bar (29.59 psi)

Holding time: 3 min

Steam sterilizers that comply with the requirements of either EN 13060, class B (for example, DAC PROFESSIONAL) or EN 13060, class S and are also suitable for the sterilization of turbines are approved.

NOTICE! Do not exceed 140°C (284°F), even during the drying phase.

The turbine can be sterilized in packaging which is suitable for sterilization and storage, e.g. paper/plastic composite packaging.

After sterilizing

1. Remove the turbine from the steam sterilizer immediately.
CAUTION! The turbine will be hot. This may cause burns!
NOTICE! Do **not** immerse the turbine in cold water to speed up the cooling process. This will damage your turbine!
2. Store all turbines so that they are protected from contamination.
3. Sterilize again once the storage period has elapsed.

7.8 Cleaning the cooling spray nozzles

If your tap water is very hard, lime deposits may constrict or completely block the cooling spray nozzles.

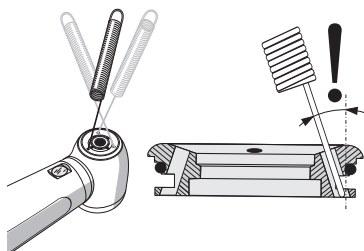

1. Carefully clean the nozzle openings by running a cleaning wire through them at regular intervals.
2. Let the turbine run briefly with cooling spray.

7.9 Replacing the spray insert

Required accessories

- 3-nozzle spray ring set
- Tool set for spray ring replacement

Removing and cleaning the spray insert

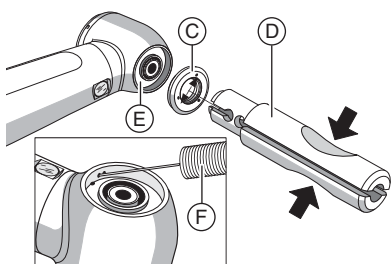
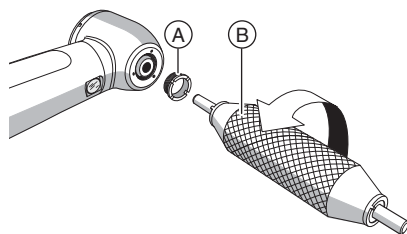

1. Remove the burr from the head.
2. Clean any deposits off of the front end of the head.
3. Unscrew the spray screw (A) with the spray wrench (B) by turning counterclockwise.
Tip: The thin tip of the spray wrench is suitable for FG contra-angle handpieces.
4. Insert the dismantling tool (D) into the spray insert (C).
5. Press the recessed grips of the dismantling tool together and pull the spray insert out of the head.
NOTICE! Do **not** reuse this O-ring or the spray screw.
6. Thoroughly clean the air/water mixing chamber (E) in the head.
7. Carefully clean the air and water ducts with the cleaning wire (F).
8. Then rinse the ducts thoroughly by letting the turbine run briefly with spray.

Inserting the spray insert

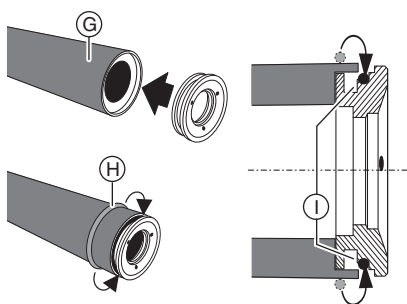

1. Push the spray adapter fully into the push-on sleeve (G) and slide on a new O-ring (H).
NOTICE! The O-ring must not get stuck in the ring channel (I).
2. Spray the O-ring with T1 spray.
3. Determine the position of the spray nozzle(s) and reinsert the spray insert into the head.
4. Using the spray key, tighten the spray insert with a new spray screw.
CAUTION! Be careful to screw the spray insert on tightly. Otherwise the spray insert may come off and it and the spray screw can fall into the patient's pharynx.
5. Let the turbine run with cooling spray and check the spray discharge.

7.10 Testing the FG clamping system

Interval

Test the FG clamping system at least once a month.

Required accessories

Chuck tester

Procedure

- ✓ The expiry date of the chuck tester (A) has **not** elapsed.
- 1. Insert the chuck tester into the FG clamping system [→ 13].
- 2. Tighten the chuck tester until the marking ring appears (withdrawal force: 22 N)

Does the chuck tester slide out of the chuck before the marking ring appears?

CAUTION! The chuck is defective and the secure fit of the burr instrument is not guaranteed. This may cause injury!

1. Do not use the product.
2. Have the clamping system replaced by a workshop authorized by Sirona.

Tip: Record the time and result of the check for your own information.

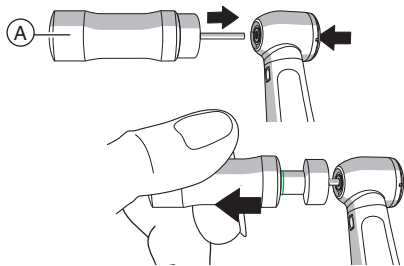

7.11 Servicing Sirona quick coupling

7.11.1 Replacing O-rings

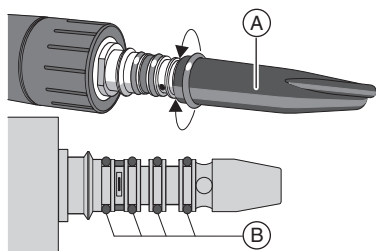

1. Remove the defective O-ring.
2. Slide the tool (A), with the new O-ring attached, to just in front of the corresponding groove (B).
3. Insert the O-ring. Do **not** use any sharp objects for this.
4. Lightly oil the O-ring with T1 spray.
NOTICE! Do **not** use Vaseline or silicone grease on the O-rings.

7.11.2 Replacing the compression ring

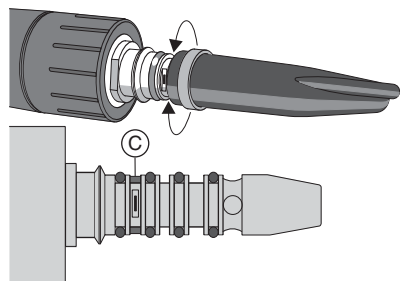

In order to guarantee proper functioning of the “back suction stop in the spray water duct”, we recommend replacing the compression ring (C) every six months.

1. Purge the spray water duct at the maximum water flow.
2. Slide the tool, with the new compression ring attached, to just in front of the corresponding groove (C).
3. Insert the compression ring. Do **not** use any sharp objects.
4. Check that the ring fits snugly all the way around and is **not** twisted.

7.11.3 Replacing the halogen lamp/LED

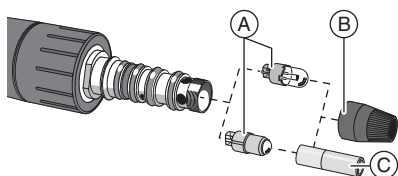

CAUTION! The halogen lamp/LED can be hot. There is a risk of burns! Allow the halogen lamp/LED to cool down.

1. Remove the turbine.
2. Unscrew the cap (B).
3. Remove the defective halogen lamp/LED (A).
4. Insert the new halogen lamp/LED. Ensure the proper position of the contact surfaces.
NOTICE! Pressing on the lens can destroy the LED. Therefore, please use the installation tool (C) provided to insert the LED.
5. Wipe the bulb of the halogen lamp with a clean cloth.
6. Unscrew the cap from the quick coupling.
7. Check the light function of the quick coupling.

Does the LED not light up?

- > Remove the LED and re-insert it after rotating it 180° around its own axis.

7.11.4 Replacing the spray water cartridge

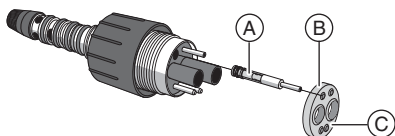

Required accessories

- Spray water cartridge
- T1 spray

If the spray water cartridge leaks or is clogged.

1. Remove the quick coupling from the supply hose.
2. Remove the sealing washer (B).
3. Click the control ring into the maximum water flow. The spray water cartridge (A) can be replaced **only** in this position.
4. Remove the spray water cartridge.
5. Spray oil lightly onto the new spray water cartridge.
6. Insert the new spray water cartridge.
7. Note the position of the bulging side (C) when fitting the sealing washer.

7.11.5 Replacing the felt strip (quick coupling F)

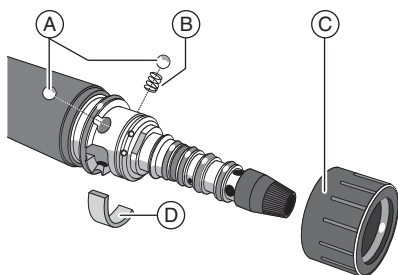

Replace the felt strip if the oil-laden return air that escapes is soiled. We recommend replacing the felt strip at least every three months.

1. Click the control ring into the maximum water flow.
2. Place the coupling upright on a firm, flat surface supported by the screw-on cap and firmly push the control ring (C) downward until it disengages.
NOTICE! Note that the balls (A) and springs (B) may drop out.
3. Replace the soiled felt strip (D).
4. Click the control ring back into position, taking care to keep the balls and springs in place.

7.12 Replacing the halogen lamp in the handpiece

For turbines with W&H or Bien-Air connection, the halogen lamp is located in the turbine handpiece.

T1 turbine with W&H connection:

CAUTION! The halogen lamp may be hot. This may cause burns! Allow the halogen lamp to cool down.

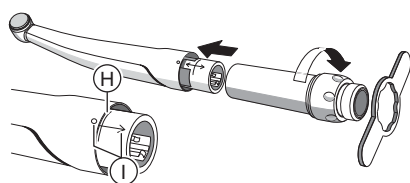
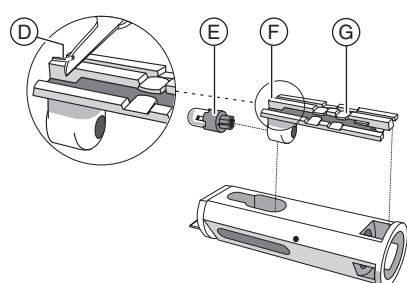
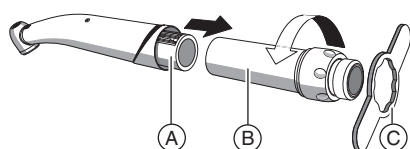

1. Detach the turbine from the quick coupling.
2. Unscrew end sleeve (B) with the tool (C) supplied and detach it.
3. Detach the coupling fitting (A).
4. Remove the lamp holder (G) from the coupling fitting. To do so, lift the lamp holder at the head end (F).
5. Tap the defective halogen lamp (E) out of its base.
6. Insert the new halogen lamp. Ensure the correct position of the contact surface.
7. Wipe the bulb with a clean cloth.
8. Insert the lamp holder.
When using a new lamp holder, remove the small bar (D) before insertion.
9. Carefully push the coupling fitting in up to marking line (H).
↪ The arrow on the coupling fitting and the dot on the handpiece must face each other (I).
10. Refit end sleeve and screw it down with tool.

T2 turbine with W&H connection:

CAUTION! The halogen lamp may be hot. This may cause burns! Allow the halogen lamp to cool down.

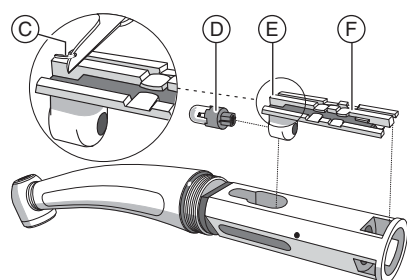
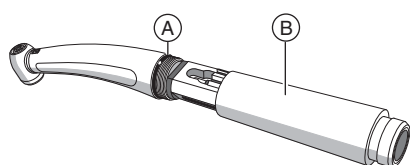

1. Detach the turbine from the quick coupling.
2. Unscrew the back (B) of the handpiece sleeve and remove it.
3. Check the O-ring (A) for damage and replace it if necessary.
4. Lift the lamp holder (F) at the head end (E) and remove it.
5. Tap the defective halogen lamp (D) out of its base.
6. Insert the new halogen lamp. Ensure the correct position of the contact surface.
7. Wipe the bulb with a clean cloth.
8. Insert the lamp holder.
When using a new lamp holder, remove the small bar (C) before insertion.
9. Screw the handpiece sleeve back on.

T1 turbine with Bien-Air connection:

CAUTION! The halogen lamp may be hot. This may cause burns! Allow the halogen lamp to cool down.

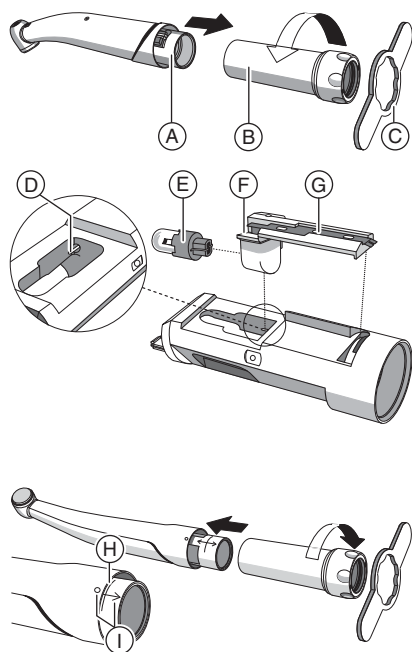

1. Detach the turbine from the quick coupling.
2. Unscrew end sleeve (B) with the tool (C) supplied and detach it.
3. Detach the coupling fitting (A).
4. Remove the lamp holder (G) from the coupling fitting. To do this, lift the lamp holder at the corner (F) using a fingernail.
NOTICE! Take care that the contact pin (D) does **not** become bent or damaged at the coupling fitting.
5. Pull the defective halogen lamp (E) out of its base.
6. Insert the new halogen lamp. Ensure the proper position of the contact surface.
7. Wipe the bulb with a clean cloth.
8. Insert the lamp holder. In doing so, pay attention to the contact pin.
9. Carefully push in coupling fitting up to marking line (H).
↳ The arrow on the coupling fitting and the dot on the handpiece must face each other (I).
10. Insert the end sleeve and screw it tight with the tool.

T2 turbine with Bien-Air connection:

CAUTION! The halogen lamp may be hot. This may cause burns! Allow the halogen lamp to cool down.

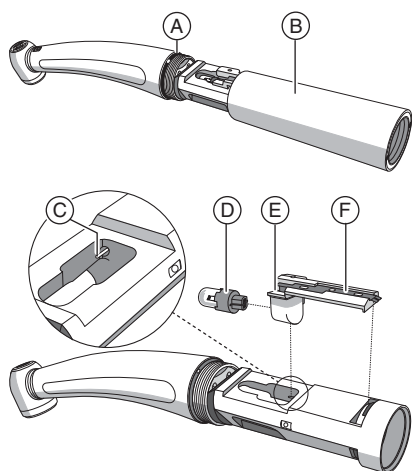

1. Detach the turbine from the quick coupling.
2. Unscrew the back (B) of the handpiece sleeve and remove it.
3. Check the O-ring (A) for damage and replace it if necessary.
4. Lift the lamp holder (F) at the corner (E) with a fingernail and remove it.
NOTICE! Take care that the contact pin (C) does **not** become bent or damaged at the coupling fitting.
5. Pull the defective halogen lamp (D) out of the socket.
6. Insert the new halogen lamp. Ensure the proper position of the contact surface.
7. Wipe the bulb with a clean cloth.
8. Insert the lamp holder. In doing so, pay attention to the contact pin.
9. Screw the handpiece sleeve back on.

8 Spare parts and consumables

Use only Sirona original or approved parts.

	Order ID:		Order ID:
T1 spray (6 x 250 ml cans)	59 01 665	Halogen lamp (dark brown base)	59 40 291
3-nozzle spray ring set (with spare parts)	58 66 715	3-nozzle service set (with tools)	58 66 749
Tool set for spray ring replacement	62 59 605	Cleaning wire for spray nozzles	24 00 232
Chuck tester	33 27 793		

Turbine with Sirona connection

	Order ID:		Order ID:
Spray adapter	59 41 802	O-ring for spray adapter	18 91 840
Replacement kit for quick coupling: <ul style="list-style-type: none"> • 10 O-rings • 2 compressed rings • 1 tool for O-rings and compressed rings 	41 75 803	Tool for O-rings and compressed rings	41 74 343
		Screw-on cap for R/F coupling	89 16 645
		Wrench for quick coupling	59 41 794
		LED for R/F coupling	63 14 558
Spring coupling F	89 17 262	Control ring coupling F	41 76 603
2.5 mm Ø ball for coupling F	34 20 742	Felt strip coupling F	41 76 389
Sealing washer for R/F quick coupling	89 16 629	Spray water cartridge for R/F coupling	77 43 444

Turbine with KaVo connection

	Order ID:		Order ID:
Spray adapter	54 56 954	O-rings (small) for spray adapter	18 90 842
O-ring (large) for spray adapter	18 91 444		

Turbine with W&H connection

	Order ID:		Order ID:
Spray adapter	54 56 970	O-ring (small) for spray adapter	41 83 849
O-ring (large) for spray adapter	70 23 542	Tool for replacing lamps	54 57 515
Lamp holder	54 56 871		

Turbine with NSK connection

	Order ID:		Order ID:
Spray adapter (QD-J)	58 62 243	Spray adapter (NSK ML)	58 67 911
O-ring (large) for spray adapter (QD-J)	41 83 856	O-ring set (NSK ML)	58 74 958
O-rings (small) for spray adapter (QD-J)	70 41 734		

Turbine with Bien-Air connection

	Order ID:		Order ID:
Spray adapter	58 29 796	O-ring (small) for spray adapter	41 83 849
O-ring (large) for spray adapter	70 36 890	Tool for replacing lamps	54 57 515
Lamp holder	58 55 577		

9 Storage and transport conditions



Protect against moisture



Sensitive contents

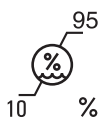

Relative humidity

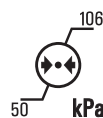

Air pressure

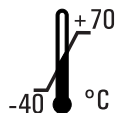

Temperature

After a severe change in temperature, allow sufficient time for acclimatization.

10 Disposal

- According to current information, the product does not contain any substances that are hazardous to the environment.
- Disinfect the product prior to disposal.
- Observe the applicable disposal regulations for your area.

We reserve the right to make any alterations which may be required due to technical improvements.

© Sirona Dental Systems GmbH 2013
D 3355.201.01.10.02 02.2013

Sprache: englisch
A.-Nr.: 116 025

Printed in Germany

Sirona Dental Systems GmbH

Fabrikstraße 31
64625 Bensheim
Germany
www.sirona.com

in the USA:

Sirona Dental Systems LLC
4835 Sirona Drive, Suite 100
Charlotte, NC 28273
USA

Order No

62 78 480 D 3355